

# Installation Manual

## for 603S & SK Wireless Intercom System

### Installation

- 1) Before installing fully, test the range of the system. Wire the unit as per wiring diagram, place the equipment in the desired location and test operation.
- 2) Ensure that the gate transmitter / receiver unit is installed to facilitate line of sight with the property or reception area. To achieve best results, mount the unit as high as possible from the ground. Should you need to extend range, you can mount it on a small pole to elevate it a few meters from the ground.

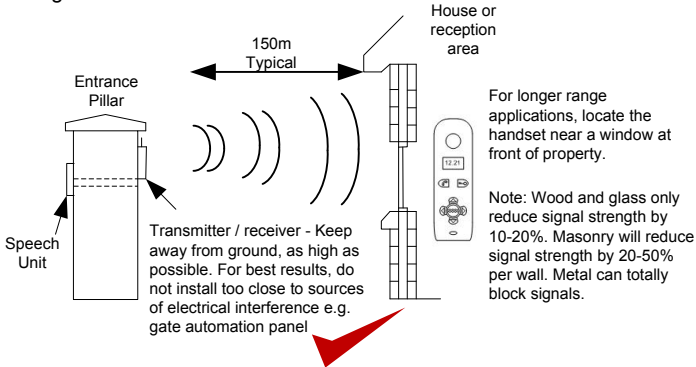

- 3) It is recommended to charge the handset for 7-8 hours before use.
- 4) Power up the handset after inserting the batteries.
- 5) Wire the door station and transmitter / receiver according to the diagram below..

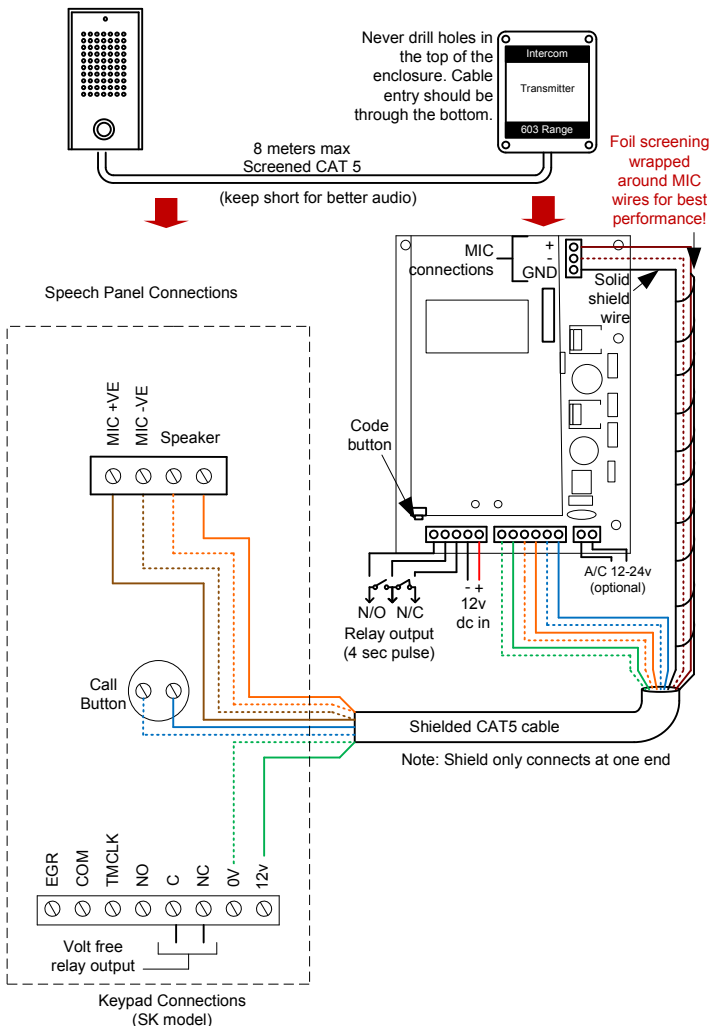

### Testing

- 1) Check all connections are correct before switching on the power.
- 2) Press the call button on the speech panel.
- 3) The handset should ring.
- 4) Press the button to answer the call and check two way speech.
- 5) Press to check the door / gate release function works.

### Handset & Operation

#### ADJUST VOLUME

Press or to adjust volume level, and press MENU to select and save.

#### CHANGE RING TONE

Press and the unit will ring under the currently select tone. Press and to cycle through available ring tones. Press MENU to select and save.

#### CHANGE LANGUAGE

Press and the unit will display the currently selected language. 1=English. Press and to cycle. Press MENU to select and save.

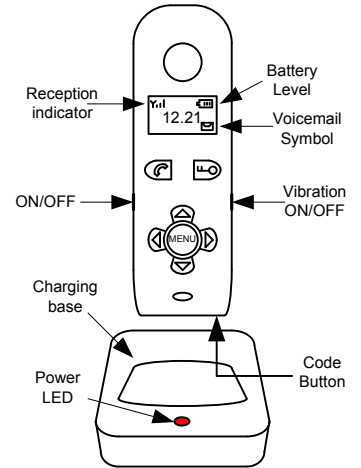

#### VOICEMAIL

When the door station is pressed, and not answered within 20 seconds, the visitor can leave a message. Once complete, the handset will display the symbol. Up to 16 messages can be saved.

To listen to voicemail, press MENU to play. If there are more than 1 message, press and to select the message required and press MENU to play.

= Pause / Exit    = Continue    = Delete, long press = delete all.

#### SET TIME ON DISPLAY

Press MENU for 2 seconds. The hour digits will begin flashing. Press or to adjust. Press MENU to cycle from hour setting to minutes and repeat. Press MENU a third time to exit and save changes.

### Coding another handset to the System

- To add an extra handset to the system, follow the sequence below..
- 1) Press and HOLD the code button on the door station until the red strobe light on the top of the working handset begins flashing.
  - 2) Press the MENU button on the working handset immediately to enable coding mode and allow other handsets to be coded.
  - 3) Press and hold the Code button on the new handset until you hear a confirmation tone "Di-Do".
  - 4) Once the door station lights stop flashing, then you can test the system by pressing the call button on the door station. The new handset should ring. If not, repeat the process from the top.

### Keypad Programming (only for SK model)

For most installations, it is sufficient to add a single keypad code for all users. On the keypad, enter...

The unit is now in programming mode. Sounder & LED will pulse

??? is your new user code.

#### Changing Programmers Code...

While in programming mode, enter the sequence shown. 0 is the location of the master code. ??? will be your new master code.

\* is to exit programming mode.